



20" PUSH/PULL STEEL LAWN ROLLER

Model 98383

ASSEMBLY, OPERATING, AND MAINTENANCE INSTRUCTIONS



Diagrams within this manual may not be drawn proportionally.
Due to continuing improvements, actual product may differ slightly from the product described herein.

Distributed exclusively by Harbor Freight Tools®.

3491 Mission Oaks Blvd., Camarillo, CA 93011

Visit our website at: <http://www.harborfreight.com>



**Read this material before using this product.
Failure to do so can result in serious injury.
SAVE THIS MANUAL.**

Copyright© 2008 by Harbor Freight Tools®. All rights reserved. No portion of this manual or any artwork contained herein may be reproduced in any shape or form without the express written consent of Harbor Freight Tools.

For technical questions or replacement parts, please call 1-800-444-3353.

SAVE THIS MANUAL

Keep this manual for the safety warnings and precautions, assembly, operating, inspection, maintenance and cleaning procedures. Write the product's serial number in the back of the manual near the assembly diagram (or month and year of purchase if product has no number). Keep this manual and the receipt in a safe and dry place for future reference.

IMPORTANT SAFETY INSTRUCTIONS

In this manual, on the labeling, and all other information provided with this product:



This is the safety alert symbol. It is used to alert you to potential personal injury hazards. Obey all safety messages that follow this symbol to avoid possible injury or death.

DANGER

DANGER indicates a hazardous situation which, if not avoided, will result in death or serious injury.

WARNING

WARNING indicates a hazardous situation which, if not avoided, could result in death or serious injury.

CAUTION

CAUTION, used with the safety alert symbol, indicates a hazardous situation which, if not avoided, could result in minor or moderate injury.



NOTICE

NOTICE is used to address practices not related to personal injury.

CAUTION

CAUTION, without the safety alert symbol, is used to address practices not related to personal injury.

GENERAL AND SPECIFIC SAFETY RULES

-  To protect your feet, always wear steel toed shoes or boots when working with this Steel Lawn Roller.
-  Wear ANSI-approved safety goggles and heavy-duty work gloves. Use face or dust mask if operation is dusty.
- Use only on flat, level surfaces. Weight of Steel Lawn Roller if used on angle surfaces may cause a loss of control and possible severe injury.
- Do not Overreach - Keep proper footing and balance at all times.
- Stay Alert - Watch what you are doing. Use common sense. Do not operate this tool when you are tired.

5. Keep hands and feet away from Roller Barrel when using. Never stand in the direct path of the Roller.
6. Do not Use on wet, or damp lawn or dirt. Grass, mud and debris can build up at Roller Barrel Axle and/or against the Scraper Plate (6) causing the Barrel to become hard to push.
7. Keep Children Away and never allow them to play with this Steel Lawn Roller. All visitors should be kept at a distance from work area. Keep pets out of the work area.
8. When servicing use only identical replacement parts.
9. When not in use, store this Steel Lawn Roller Indoors.
10. Maintain Steel Lawn Roller with care. Keep Roller Barrel clean for best performance. Inspect Steel Lawn Roller periodically, and if damaged, have it repaired by an authorized service facility. Keep handles dry, clean, and free from oil and grease.
11. Do not use this Steel Lawn Roller for other than intended use.
12. Maintain labels and nameplates on the appliance. These carry important safety information. If unreadable or missing, contact Harbor Freight Tools for a replacement.
13. The warnings, precautions, and instructions discussed in this instruction manual cannot cover all possible conditions and situations that may occur. It must be understood by the operator that common sense and caution are factors which cannot be built into this product, but must be

supplied by the operator.

 **SAVE THESE INSTRUCTIONS.**

SPECIFICATIONS

Construction	Roller Barrel: Formed, Round Steel. Upper and Lower Handle: Formed Steel. All Hardware: Carbon Steel. Drain Plug: Hard Rubber.
Overall Height	42-1/2" High
Net Weight	23.40 LB (Empty)

UNPACKING

When unpacking, check to make sure that the item is intact and undamaged. If any parts are missing or broken, please call Harbor Freight Tools at the number shown on the cover of this manual as soon as possible.

Note: For additional information regarding the parts listed in the following pages, refer to the Assembly Diagram near the end of this manual.

ASSEMBLY

1. Mount the two Lower Handles (7) to the axle of the Roller Barrel (1) and secure each side with a Cap Nut (3).
2. Mount the Top Handle (10) to the Lower Handles (7) using the Bolts (8) and the Lock-Washer Nuts (9). Refer to "Assembly Diagram" on page 6 for

correct insertion direction for Bolts (8).

3. Attach the Scraper Plate (6) through the existing holes in each of the Lower Handles (7) using the Nuts (5) and the Bolts (4).

Figure 1

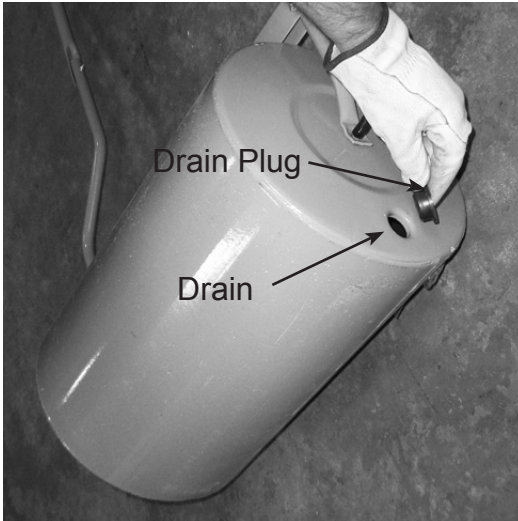

4. Add weight to the Steel Lawn Roller by standing the empty Roller Barrel on it's side with the Drain Hole up. Remove the Drain Plug (2), then using a funnel (not supplied) carefully pour water or sand into the opening until full. (Sand would give maximum weight.) See **Figure 1**.
5. Using two people for added safety, carefully lay the Steel Lawn Roller onto the ground.

OPERATING INSTRUCTIONS



Read the **ENTIRE IMPORTANT SAFETY INFORMATION** section at the beginning of this manual including all text under

subheadings therein before set up or use of this product.

1. Before operating the Steel Lawn Roller, put on ANSI-approved safety goggles, steel toe shoes and other safety gear. Safety goggles and other safety gear are sold separately.
2. Roll the Steel Lawn Roller to the area to be compacted.
3. Use the Steel Lawn Roller as you would if you were mowing a lawn. Roll one direction until all areas are rolled, then roll the other direction till area is completely rolled again.
4. If it is necessary to wash or clean debris from the Roller Barrel before you are finished using it, be sure to dry the surface with a towel or absorbent cloth to prevent a quick build up of added debris.
5. When completely finished with your project, wash off the Steel Lawn Roller with a hose and soft rag or brush and let stand until completely dry before storing. Store in garage or shed away from children.

MAINTENANCE AND SERVICING

TO PREVENT SERIOUS INJURY FROM TOOL FAILURE:

Do not use damaged equipment. If anything abnormal is noticed, or occurs while using, have the problem corrected before further use.



Procedures not specifically explained in this manual must be performed only by a qualified technician.

Cleaning, Maintenance, and Lubrication

1. Use a small amount of axle grease to lubricate axles periodically.
2. Before use, check for cracks in Top and Lower Handles and/or in Roller Barrel. If any damage is found, have the problem repaired before using.
3. After using, wipe away all dirt and debris with clean, damp (with water) cloth, then dry and store inside away from children.
4. Never put lubricants over the Roller Barrel.

NOTE: If the Steel Lawn Roller has been filled with water and is to be stored for an extended period of time, empty the water by removing the Drain Plug and allowing the water to drain completely. Dry sand may remain inside the Roller Barrel while stored.

PLEASE READ THE FOLLOWING CAREFULLY

THE MANUFACTURER AND/OR DISTRIBUTOR HAS PROVIDED THE PARTS LIST AND ASSEMBLY DIAGRAM IN THIS MANUAL AS A REFERENCE TOOL ONLY. NEITHER THE MANUFACTURER OR DISTRIBUTOR MAKES ANY REPRESENTATION OR WARRANTY OF ANY KIND TO THE BUYER THAT HE OR SHE IS QUALIFIED TO MAKE ANY REPAIRS TO THE PRODUCT, OR THAT HE OR SHE IS QUALIFIED TO REPLACE ANY PARTS OF THE PRODUCT. IN FACT, THE MANUFACTURER AND/OR DISTRIBUTOR EXPRESSLY STATES THAT ALL REPAIRS AND PARTS REPLACEMENTS SHOULD BE UNDERTAKEN BY CERTIFIED AND LICENSED TECHNICIANS, AND NOT BY THE BUYER. THE BUYER ASSUMES ALL RISK AND LIABILITY ARISING OUT OF HIS OR HER REPAIRS TO THE ORIGINAL PRODUCT OR REPLACEMENT PARTS THERETO, OR ARISING OUT OF HIS OR HER INSTALLATION OF REPLACEMENT PARTS THERETO.

PARTS LIST

Part #	Description	Q'ty
1	Roller Barrel	1
2	Drain Plug	1
3	Cap Nut	2
4	Bolt (M6x35)	2
5	Nut (M6)	2
6	Scraper Plate	2
7	Lower Handle	2
8	Bolt (M5 X 30)	2
9	Lock-Washer Nut (M5)	2
10	Top Handle	1

ASSEMBLY DIAGRAM

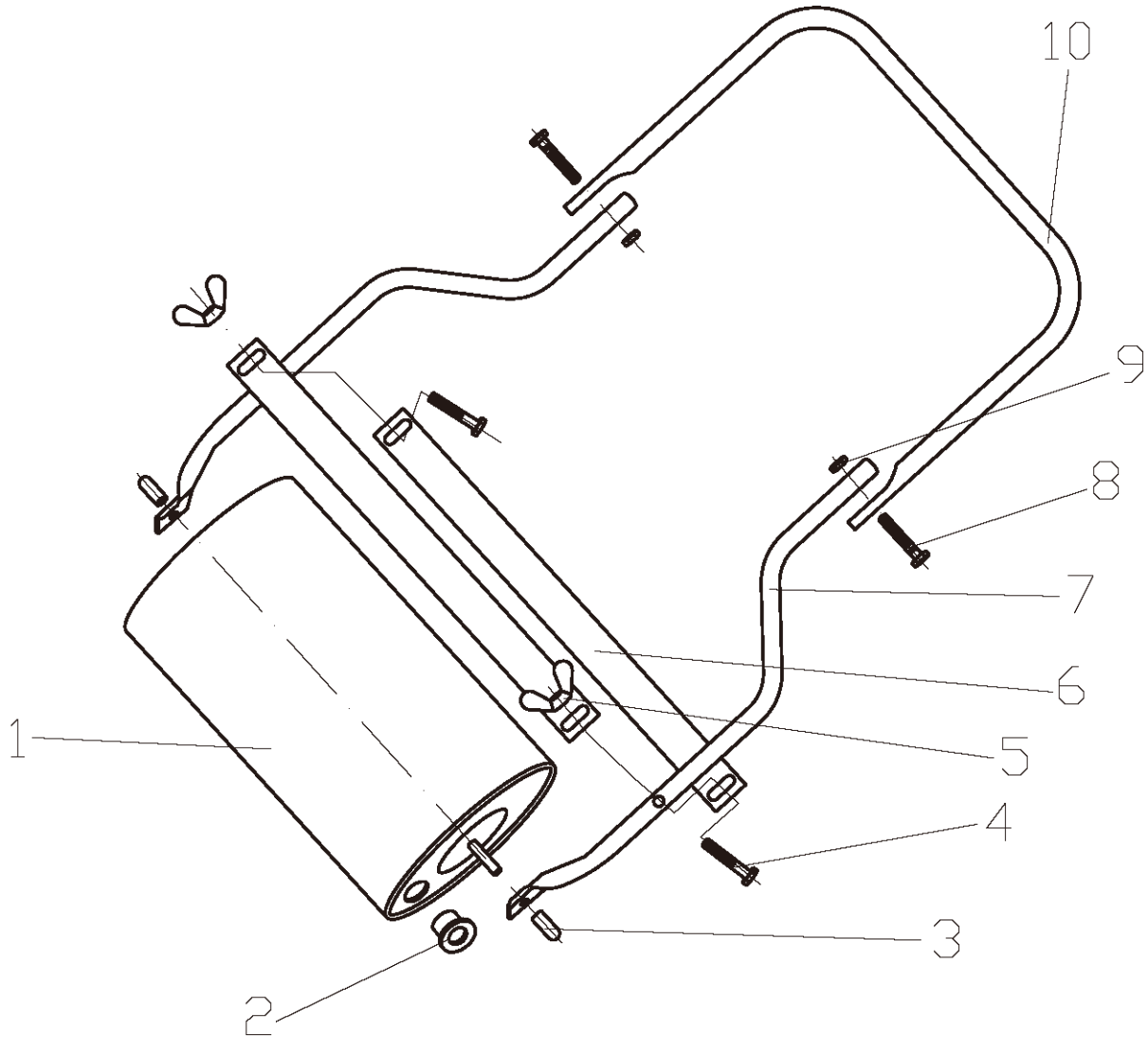

Record Product's Serial Number Here: _____

Note: If product has no serial number, record month and year of purchase instead.

Note: Some parts are listed and shown for illustration purposes only, and are not available individually as replacement parts.